

STI Call Point Stopper®



STI-6930



STI-6930-G



STI-6930-Y

PRODUCT OVERVIEW

Protective cover helps prevent malicious or accidental damage to electrical switches and call points. The Call Point Stopper is an aesthetic, inexpensive cover which provides a secure fit to a wide range of electrical switches and call points. The cover prevents misuse to the device without restricting legitimate operation. It is ideal for shopping centres, hotels, schools, colleges, hospitals, nursing homes and all public buildings where there is a risk of malicious or accidental activation.

HOW IT WORKS

The Call Point Stopper consists of a clear, tamperproof, tough polycarbonate hinged cover that retrofits securely over the existing device. Simply lift the cover to gain access to the device. Once the cover is released the spring loaded hinge returns the cover to its original position.

KEY FEATURES

General Information

- Protective cover helps prevent malicious or accidental damage to electrical switches and call points.
- Three year guarantee against breakage of polycarbonate in normal use.

Design

- Prevents unwanted or accidental use, without hindering legitimate operation of a manual call point in the event of an emergency.
- Spring loaded hinge mechanism.

Construction

- Tough polycarbonate housing can withstand the severest of knocks.

Installation

- A simple 4 fixing installation can retrofit over existing device.
- Can accommodate flush or surface mounted applications.
- Polycarbonate tested -40°C (-40°F) to 49°C (120°F).

Options

- Available in a range of colours.
- Custom labelling available.

STI Call Point Stopper®

Dimensions and Technical Information

MODELS AVAILABLE

- STI-6930** Call Point Stopper flush mount
- STI-6931** Call Point Stopper surface mount (includes 35mm spacer)

Accessories:

- STI-6903** 35mm spacer (supplied with STI-6931)

Options:

- COLOURS AVAILABLE** For green or yellow add -G or -Y (e.g. STI-6930-G for Call Point Stopper flush mount in green)

NB:

The Call Point Stopper is supplied in red with operating instructions: 'IN CASE OF FIRE - LIFT COVER BREAK GLASS'.
Alternative and custom markings available.

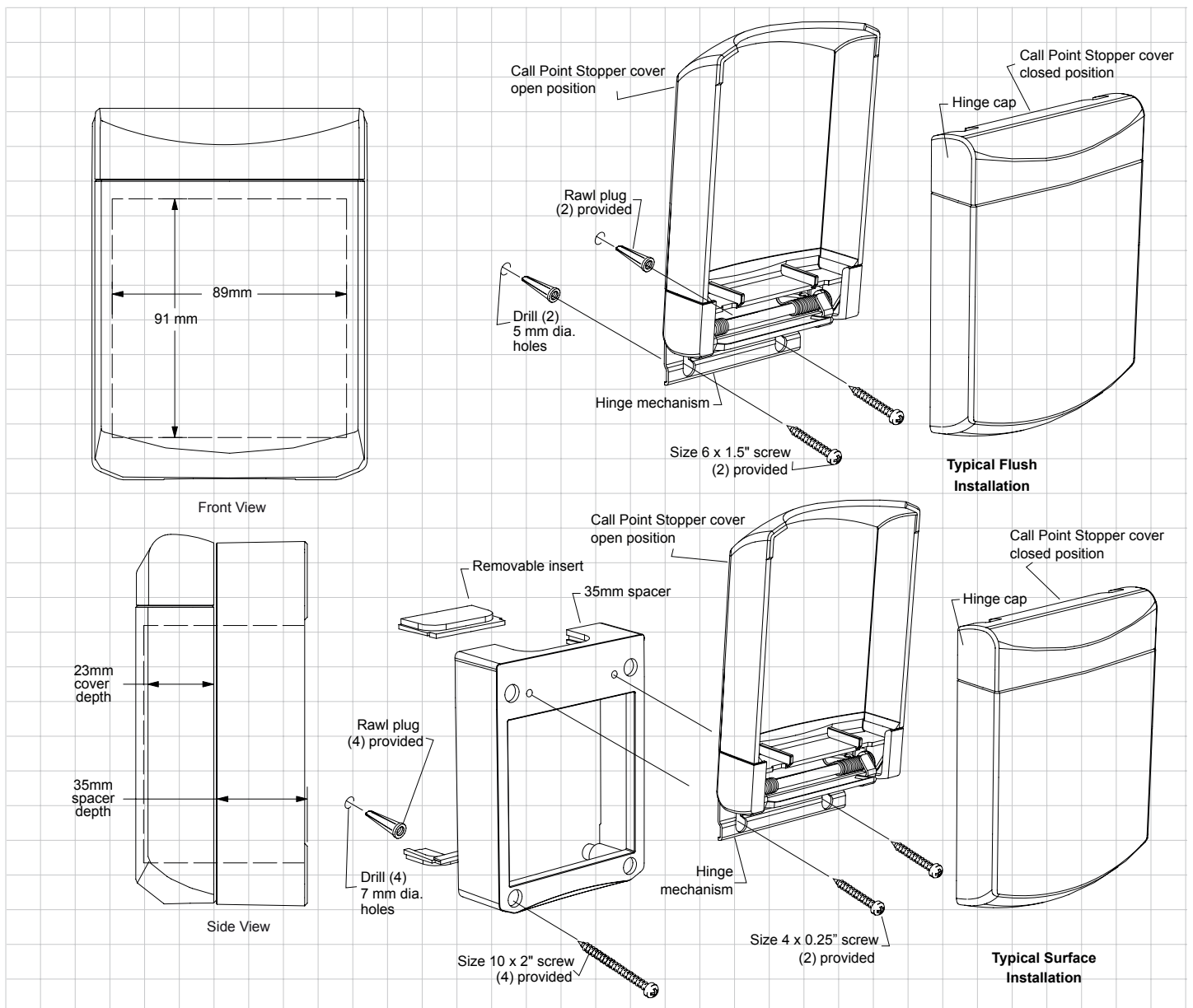

Safety Technology International

Taylor House
34 Sherwood Road
Bromsgrove
Worcestershire
B60 3DR, England

Tel: +44 (0)1527 520 999
Fax: +44 (0)1527 501 999
info@sti-emea.com
www.sti-emea.com

2306 Airport Road
Waterford, Michigan
48327, USA

Tel: 248-673-9898
Fax: 248-673-1246
Toll-free: 0800-888-4784
info@sti-usa.com
www.sti-usa.com